



DS401E FULL HEIGHT TURNSTILE
SINGLE PASSAGE

SAFETY
LEVEL

AESTHETICS

COSTING

- Full height turnstile is highest safety access control solutions.
- The body is made of brushed stainless steel which is robust, rigid, anti-rust, waterproof and durable.
- It is ideal for both indoor and outdoor settings.
- It has standard relay signal, which can be integrated with any kind of third-party access control system (e.g.: RFID, Fingerprint and Biometric reader device).
- It has sufficient space, which can be mounted with any type of external device (e.g.: Display, Counter, Reader, Push button, Card collector, Coin insert, Barcode/QR reader, Wheel).
- In case of emergency, full height turnstile horizontal arms will drop down automatically to allow free passage when power off.
- Anti-tailing function: only one person pass at one time.
- It is suitable for areas with high security. (e.g.: Embassy, Stadium, Bank, Jail, Oil Field, Construction site, Station).

Features

- ✓ Long-life performance, high operation dependability and fast response.
- ✓ The mechanism is equipped with an automatic regulated hydraulic buffer device. No noise and impact when running.
- ✓ Single directional or Bi-directional is selectable.
- ✓ Automatic reset function: turnstile arm will lock automatically within 5s (can be setting) if passenger delay to entry.
- ✓ When power is off, arms will open automatically, which is complying with fire safety requirements.
- ✓ LED indicator(red × means no entry; green → means entry).
- ✓ Easy to install and maintain.
- ✓ 3-year warranty support.
- ✓ Structure of trunking to contain cable tidy inside the case.
- ✓ Structure of ring cover on top and bottom to beautify it.

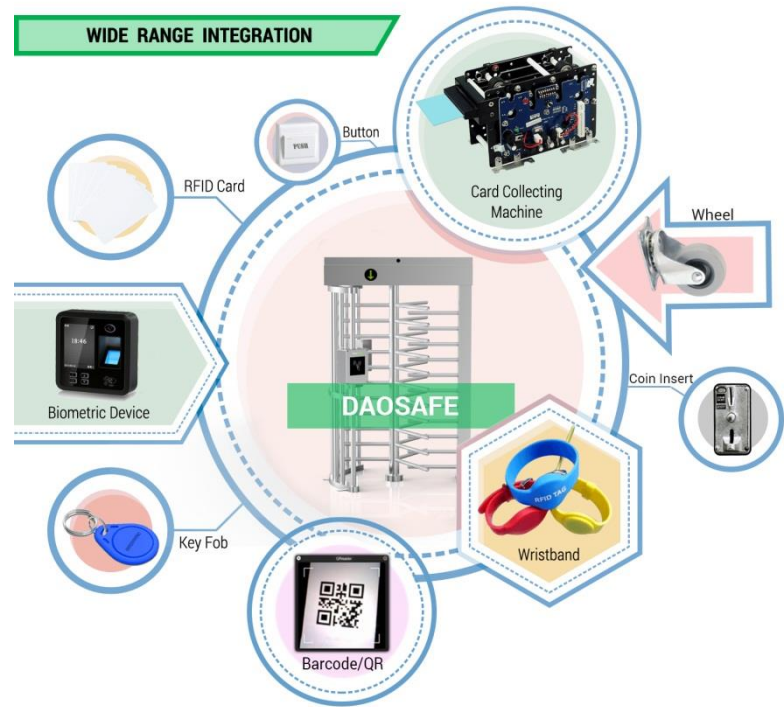

Specifications

Model No.	DS401E
Brand	Daosafe
Framework Material	304 Full Stainless Steel
Dimension	1475 * 1200* 2180mm
Weight	150kg/pcs
Passage Width	1 lane, 640mm/lane
Arm Support	120° rotors with 3 sections or 90° rotors with 4 sections
Passing Direction	Single directional / Bi-directional
MCBF	5 million
Power Supply	AC220V/110V, 50/60Hz
Operation Voltage	24V DC
Power Consumption	40W
Operation Temperature	-15 °C - 60 °C
Operation Humidity	0 ~ 95% (No freeze)
Working Environment	Indoor / Outdoor
Flow Rate	35-40 people per minute
LED Indicator	Yes
Emergency	Automatic arm open when power off
Communication	Dry contact, Relay signal, RS485

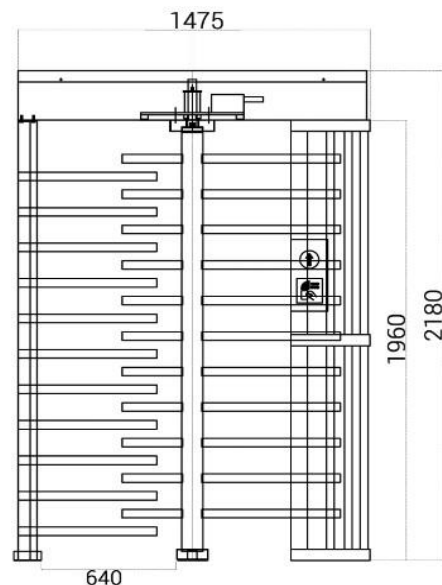
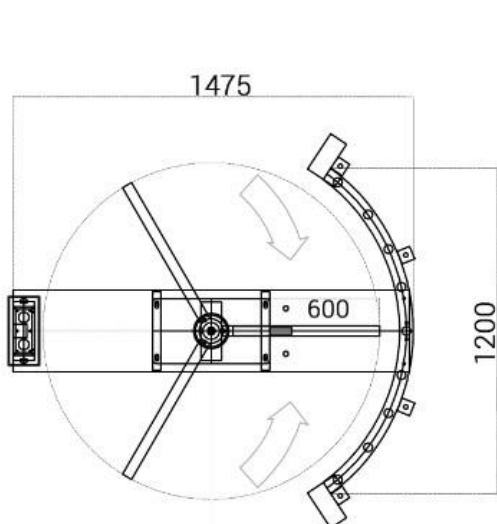

System Integration Figure

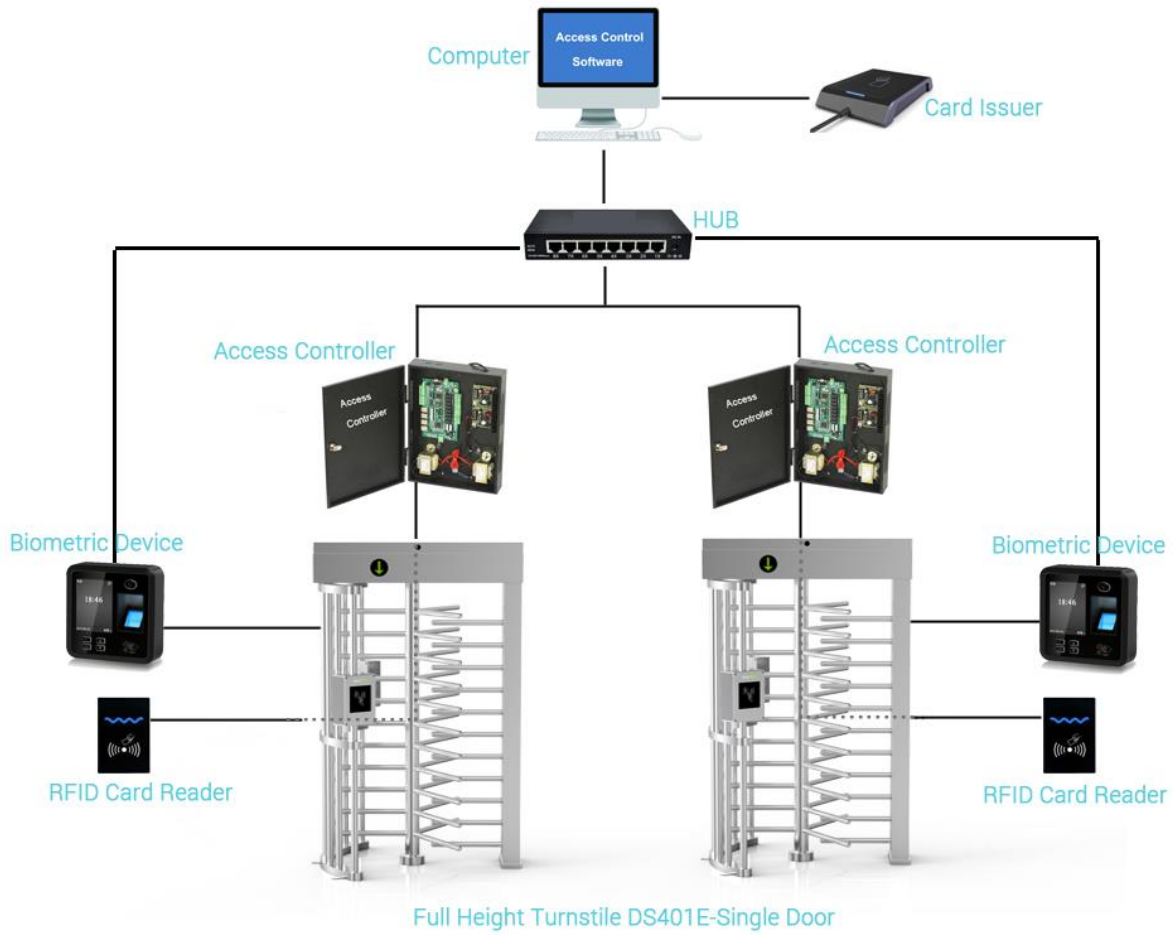

Range of Applications

